



Alarm.com Smart Thermostat (ADC-T3000) - Battery Replacement

The Alarm.com Smart Thermostat (ADC-T3000) can be powered by two AAA Alkaline batteries.

Considerations:

- If there are no batteries inserted, and the thermostat is running off solely of AC power, the thermostat will report a low battery (indicated by a caution sign and *LOW BATTERY* flashing on the display).
- Always replace the batteries as soon as they have low battery levels. If the batteries drain, the thermostat could leave the HVAC system on or off, overheating or freezing the home.
- If the thermostat buttons flash amber when pressed and the screen does not illuminate, the batteries in the thermostat are extremely low. Install fresh batteries immediately.
- Always replace the batteries at least once a year. This will protect the thermostat from damage and corrosion by leaking batteries.
- If the home is unoccupied for a month or more, such as vacation homes, replace the batteries as a preventive measure against battery failure while away.
- Always use new batteries as replacements.

To replace the batteries in the Alarm.com Smart Thermostat (ADC-T3000):

Verify the batteries are installed following the specified polarity markings on the thermostat.

1. Remove the thermostat from the back plate by pulling the thermostat straight out and off the wall.
2. Take out the existing batteries.
3. Insert the new batteries following the specified polarity markings on the thermostat.



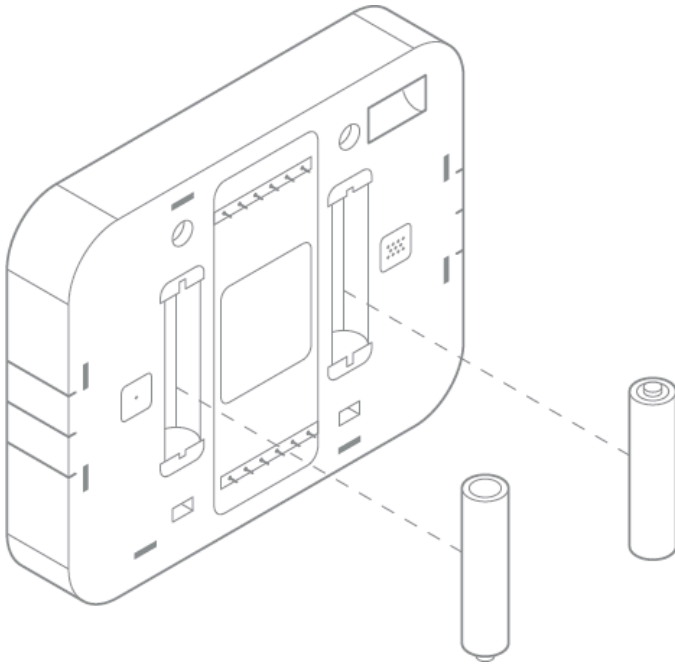

4. Return the thermostat to the wall plate by pressing the thermostat body firmly into the back plate mounted to the wall.

Important: Verify that the pins on the body are correctly aligned with the back plate. Failure to do so could cause damage to the thermostat.

